

# SNER

## Electric Chain Hoists

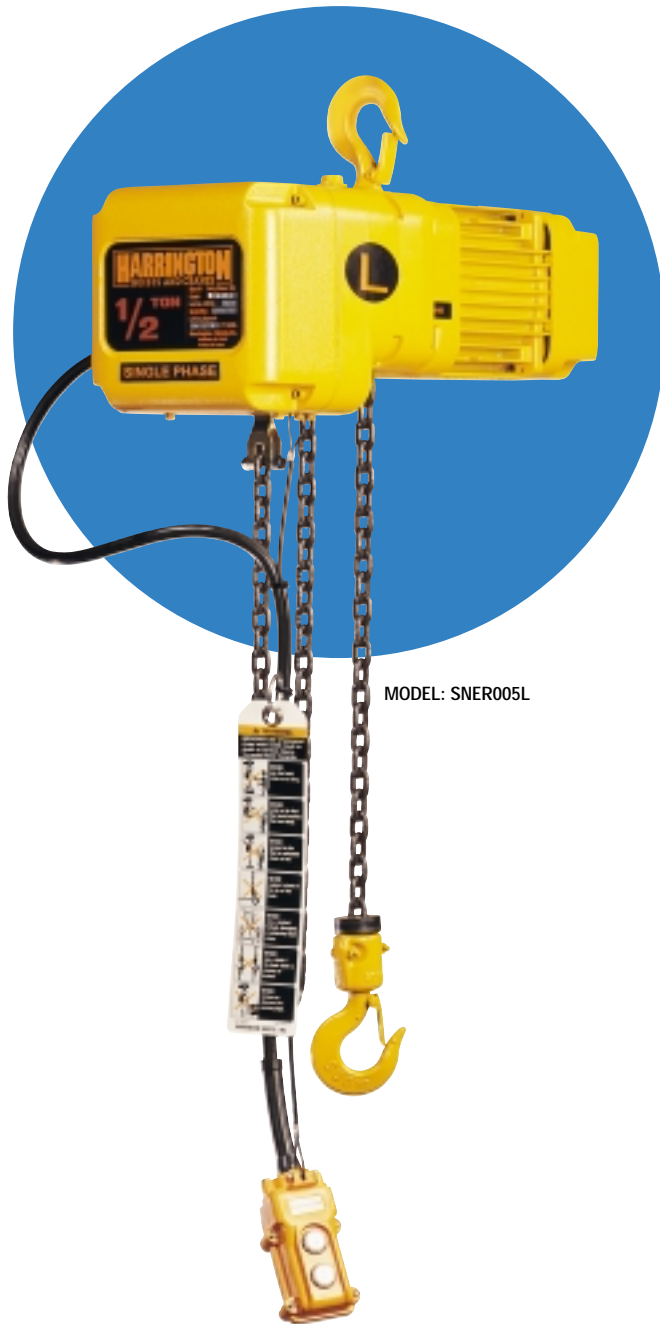

### Single Phase Power Reaches New Levels Of Performance

Harrington's SNER Series of electric chain hoists and SMR motorized trolleys offer expanded duty, low headroom and additional capacities for those many applications where only single-phase power is available. The standard features of the popular three-phase NER/MR Series are incorporated to provide the operator with top quality and high performance.

### More workplace flexibility

#### Standard Features

- 1/4–3 Ton capacities
- 115/230-1-60 reconnectable power
- Low headroom
- Lightweight and easy maintenance
- Pull-rotor motor brake
- ASME H4 classification
- NEMA 3R, IP55 rating

#### Top Quality Hoists

- 60 minute severe duty rating (fan cooled)
- Unique long life chain guide
- Friction clutch prevents lifting of overloads
- Single chain fall through 2 Tons

#### Applications

- Machine shops
- Temporary job sites
- Maintenance areas

*Ask your local sales representative or call our Customer Service staff for friendly and expert advice on models and options.*

### SNER SINGLE SPEED HOIST—SPECIFICATIONS

Cap. (Tons)	Product Code	Std. Lift (ft)	Push Button Cord L (ft)	Lifting Speed (ft/min)	Lifting Motor 1 Phase 60 Hz			Load Chain Dia. (mm) x Chain Fall Lines	Net Weight (lbs)	Weight for Additional One Foot of Lift (lbs)
					Output (Hp)	Rated Current (amps)				
						@ 115V	@ 230V			
1/4	SNER003S	10	7.2	14	0.34	7.7	3.9	5.0 x 1	82	0.37
1/2	SNER005L			7				6.3 x 1	84	0.57
1/2	SNER005S			15	0.6	16.9	8.5	6.3 x 1	104	0.57
1	SNER010L			7				8.0 x 1	110	0.93
1	SNER010S			14				8.0 x 1	159	0.93
2	SNER020L			7	1.2	23.9	12.0	10.0 x 1	174	1.5
3	SNER030C			8.2				3.5	10.0 x 2	207

### SNER SINGLE SPEED HOIST—DIMENSIONS

Cap. (Tons)	Product Code	Headroom C (in)	a (in)	b (in)	d (in)	e (in)	g (in)	h (in)	i (in)
1/4	SNER003S	13.8	22.2	13.0	10.4	11.9	0.9	4.0	3.9
1/2	SNER005L	14.0	22.2	13.0	10.4	11.9	0.9	4.0	3.9
1/2	SNER005S	14.6	23.2	13.8	10.6	12.6	0.9	4.7	4.1
1	SNER010L	16.1	23.2	13.8	10.6	12.6	1.2	4.7	4.1
1	SNER010S	17.3	26.9	16.5	12.4	14.4	1.2	6.1	5.2
2	SNER020L	22.6	26.9	16.5	12.4	14.4	1.5	6.1	5.2
3	SNER030C	29.5	26.9	16.5	12.4	14.4	1.7	8.2	3.0

### SNERM SINGLE SPEED HOIST WITH SINGLE SPEED TROLLEY—SPECIFICATIONS

Cap. (Tons)	Product Code	Std. Lift (ft)	Push Button Cord L (ft)	Lifting Speed (ft/min)	Traversing Speed (ft/min)	Lifting Motor 1 Phase 60 Hz			Traversing Motor 1 Phase 60 Hz			Flange Width Adjustability B (in)		Min. Allow. Radius for Curve (in)	Load Chain Dia. (mm) x Chain Fall Lines	Net Weight (lbs)	Weight for Additional One Foot of Lift (lbs)	
						Output (Hp)	Rated Current (amps)		Output (Hp)	Rated Current (amps)		Standard	Optional					
							@ 115V	@ 230V		@ 115V	@ 230V							
1/4	SNERM003S-L/S	10	7.5	14	L=40 S=80	0.34	7.7	3.9	0.54	8.1	4.1	2.28 to 5.00	5.01 to 6.02 OR 6.03 to 12.00	31.5	5.0 x 1	168	0.37	
1/2	SNERM005L-L/S			7											6.3 x 1	170	0.57	
1/2	SNERM005S-L/S			15		6.3 x 1	190	0.57										
1	SNERM010L-L/S			7		8.0 x 1	196	0.93										
1	SNERM010S-L/S			14		8.0 x 1	245	0.93										
2	SNERM020L-L/S			7		1.2	23.9	12.0				3.23 to 6.02	6.03 to 7.02 OR 7.03 to 12.00		39.4	10.0 x 1	276	1.5
3	SNERM030C-L/S			8.2												3.5	10.0 x 2	322

### SNERM SINGLE SPEED HOIST WITH SINGLE SPEED TROLLEY—DIMENSIONS

Cap. (Tons)	Product Code	Headroom C (in)	b (in)	b' (in)	d (in)	e (in)	e' (in)	g (in)	i (in)	j (in)	k (in)	m (in)	n (in)	r (in)	t (in)	u (in)
1/4	SNERM003S-L/S	14.6	12.4	15.6	10.6	20.3	7.0	0.9	3.74	0.9	5.1	8.0	4.3	2.0	1.22	3.2
1/2	SNERM005L-L/S	14.6	12.4	15.6	10.6	20.3	7.0	0.9	3.74	0.9	5.1	8.0	4.3	2.0	1.22	3.2
1/2	SNERM005S-L/S	15.4	12.4	15.6	10.6	20.3	7.0	0.9	3.74	0.9	5.1	8.0	4.3	2.0	1.22	3.2
1	SNERM010L-L/S	16.5	12.4	15.6	10.6	20.3	7.0	1.2	3.74	0.9	5.1	8.0	4.3	2.0	1.22	3.2
1	SNERM010S-L/S	17.7	12.4	15.6	10.6	20.3	7.0	1.2	3.74	0.9	5.1	8.0	4.3	2.0	1.22	3.2
2	SNERM020L-L/S	22.2	12.8	16.4	10.7	20.5	7.2	1.5	4.33	1.1	4.9	8.3	4.6	2.4	1.42	3.0
3	SNERM030C-L/S	28.9	13.4	17.4	10.8	20.5	7.3	1.7	4.92	1.1	5.2	8.5	5.2	2.7	1.69	2.7

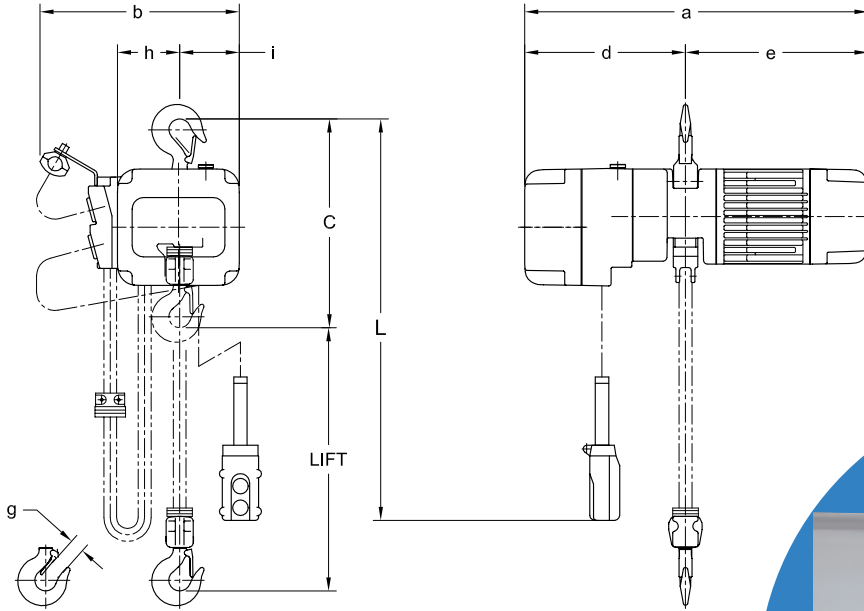

SNER005L

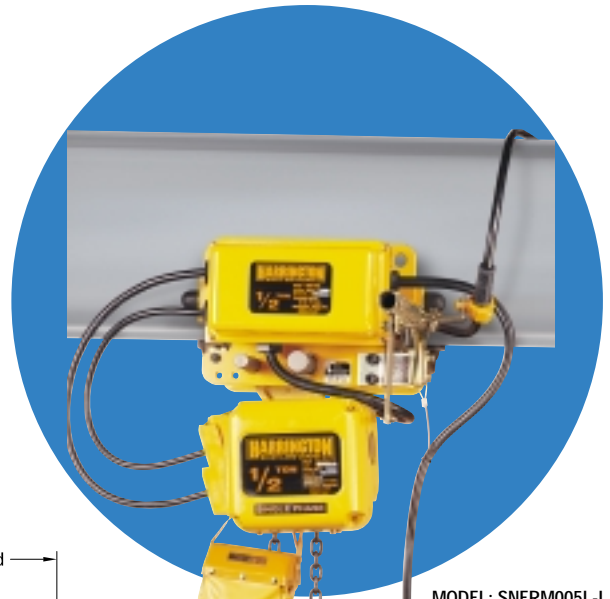

MODEL: SNERM005L-L

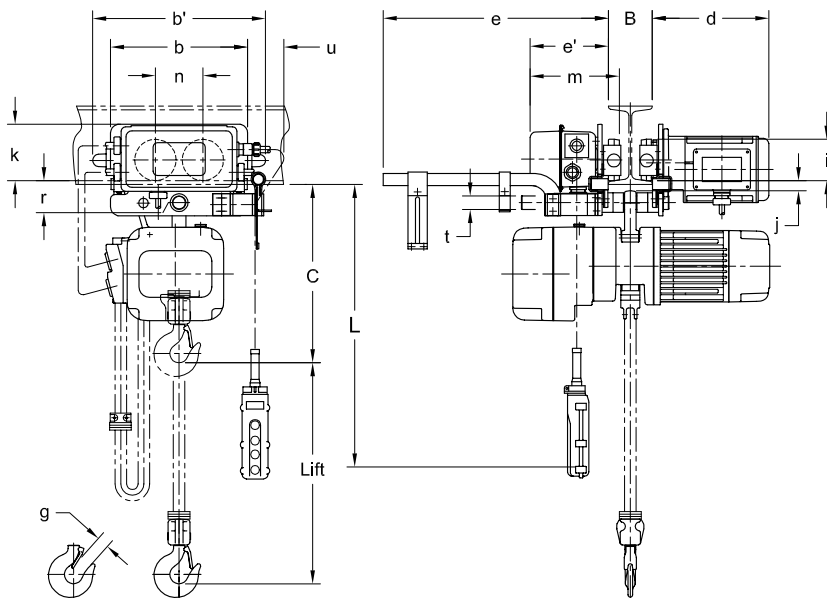

SNERM010L-L

**High Performance Trolleys**

- 30 minute heavy duty rating
- Side guide rollers for smooth travel
- Standard rubber bumpers
- Adjustable for multiple beam flanges

**SNERP/SNERG SINGLE SPEED HOIST WITH PUSH OR GEARED TROLLEY—SPECIFICATIONS**

Cap. (Tons)	Product Code	Std. Lift (ft)	Push Button Cord L (ft)	Lifting Speed (ft/min)	Lifting Motor 1 Phase 60 Hz			Flange Width Adjustability B (in)		Min.* Allow. Radius for Curve (in)	Load Chain Dia. (mm) x Chain Fall Lines	Net Weight (lbs)	Weight for Additional One Foot of Lift (lbs)				
					Output (Hp)	Rated Current (amps)		Standard	Optional								
						@ 115V	@ 230V										
1/4	SNERP(SNERG)003S	10	7.5	14	0.34	7.7	3.9	2.28 to 4.00 (2.28 to 5.00)	4.01 to 8.00 (5.01 to 8.00) OR 8.01 to 12.00	43.3 (51.2)	5.0 x 1	93 (110)	0.37 (1.0)				
1/2	SNERP(SNERG)005L			7							0.6	16.9	8.5	5.01 to 8.00 OR 8.01 to 12.00	6.3 x 1	95 (112)	0.57 (1.2)
1/2	SNERP(SNERG)005S			15											6.3 x 1	115 (135)	0.57 (1.2)
1	SNERP(SNERG)010L			7	1.2	23.9	12.0	2.28 to 5.00	5.01 to 8.00 OR 8.01 to 12.00	51.2	8.0 x 1	130 (141)	0.93 (1.5)				
1	SNERP(SNERG)010S			14							8.0 x 1	179 (190)	0.93 (1.5)				
2	SNERP(SNERG)020L			7							10.0 x 1	209 (220)	1.5 (2.2)				
3	SNERP(SNERG)030C			8.2	3.5			3.23 to 6.02	6.03 to 12.00	66.9	10.0 x 2	251 (262)	3.1 (3.7)				

Figures in parentheses are data for geared trolley.  
 \*Minimum flange width for curved beam: 1 Ton Push and 1/4 to 1 Ton Geared = 2.87 in.; 3 Ton Push and Geared = 3.50 in.

**SNERP SINGLE SPEED HOIST WITH PUSH TROLLEY—DIMENSIONS**

Cap. (Tons)	Product Code	Headroom C (in)	a (in)	b (in)	e (in)	g (in)	h (in)	i (in)	j (in)	k (in)	m (in)	n (in)	r (in)	t (in)
1/4	SNERP003S	15.4	8.0	7.2	1.8	0.9	3.2	2.36	0.7	3.0	1.9	3.3	1.5	0.87
1/2	SNERP005L	15.4	8.0	7.2	1.8	0.9	3.2	2.36	0.7	3.0	1.9	3.3	1.5	0.87
1/2	SNERP005S	16.1	8.0	7.2	1.8	0.9	3.2	2.36	0.7	3.0	1.9	3.3	1.5	0.87
1	SNERP010L	18.1	9.8	9.3	2.2	1.2	4.2	2.80	1.1	3.7	2.2	4.4	2.0	0.98
1	SNERP010S	19.5	9.8	9.3	2.2	1.2	4.2	2.80	1.1	3.7	2.2	4.4	2.0	0.98
2	SNERP020L	24.6	11.8	11.0	2.7	1.5	5.0	3.35	1.3	4.4	2.8	5.2	2.4	1.26
3	SNERP030C	29.3	12.6	12.8	3.1	1.7	5.8	3.94	1.4	5.3	3.1	6.0	2.7	1.42

**SNERG SINGLE SPEED HOIST WITH GEARED TROLLEY—DIMENSIONS**

Cap. (Tons)	Product Code	Headroom C (in)	E (in)	a (in)	b (in)	e (in)	g (in)	h (in)	i (in)	j (in)	k (in)	k' (in)	m (in)	n (in)	r (in)	t (in)	u (in)
1/4	SNERG003S	16.1	10.5	13.6	9.3	6.0	0.9	4.2	2.80	1.1	3.7	4.2	2.2	4.4	2.0	0.98	7.2
1/2	SNERG005L	16.1	10.5	13.6	9.3	6.0	0.9	4.2	2.80	1.1	3.7	4.2	2.2	4.4	2.0	0.98	7.2
1/2	SNERG005S	16.9	10.5	13.6	9.3	6.0	0.9	4.2	2.80	1.1	3.7	4.2	2.2	4.4	2.0	0.98	7.2
1	SNERG010L	18.1	10.5	13.6	9.3	6.0	1.2	4.2	2.80	1.1	3.7	4.2	2.2	4.4	2.0	0.98	7.2
1	SNERG010S	19.5	10.5	13.6	9.3	6.0	1.2	4.2	2.80	1.1	3.7	4.2	2.2	4.4	2.0	0.98	7.2
2	SNERG020L	24.6	10.5	15.2	11.0	6.1	1.5	5.0	3.35	1.3	4.4	4.3	2.7	5.2	2.4	1.26	7.2
3	SNERG030C	29.3	11.0	15.7	12.8	6.2	1.7	5.8	3.94	1.4	5.3	4.5	3.1	6.0	2.7	1.42	7.2

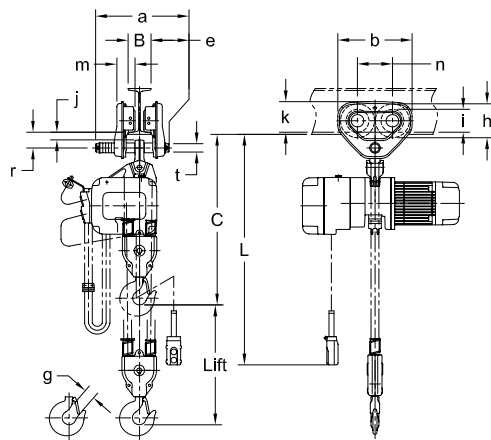

SNERP030C

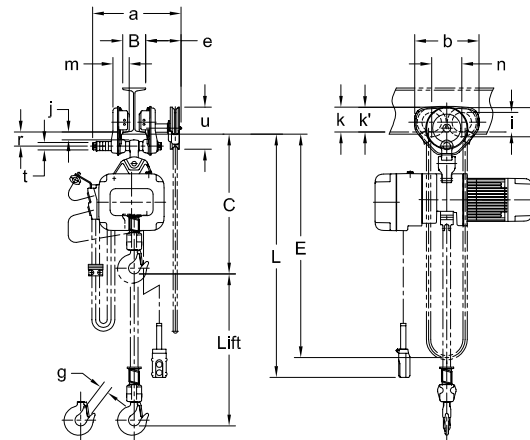

SNERG020L



Harrington Hoists, Inc.  
 401 West End Avenue, Manheim, PA 17545  
 717-665-2000 / 800-233-3010 / Fax: 717-665-2861  
 www.harringtonhoists.com

Harrington Hoists, Inc.—Western Division  
 2341 Pomona Rincon Road, No. 103  
 Corona, CA 92880-6973  
 909-279-7100 / 800-317-7111 / Fax: 909-279-7500

Specifications and dimensions are subject to change without notice.  
 Rev 0 Copyright © 2002 9-02  
 Item No. SS-SNER